

HDL[®] KNX/EIB



**Intelligent
sensor**

Guangzhou Hedong Electronic Co.,Ltd(HDL)

HDL KNX / EIB-BUS

(Intelligent Installation Systems)

Product Manual

Contents

1-General	3
1.1-Product Function	3
2- Hardware	4
2.1 Technical data	4
2.2 Dimension drawings	6
2.3 Wiring diagram	6
2.4 Range of Coverage	7
2.5 Maintenance and Cautions	8
3- Software.....	9
3.1 Database functions Overview.....	9
3.2 Object/Association/Group address define	10
3.3 Function parameter “General”	11
3.4 Function parameter “Logical function A”	15
3.4.1 Function parameter “Block A”	19
3.4.1.1 Function parameter “Switching”	20
3.4.1.2 Function parameter “Dimming”	22
3.4.1.3 Function parameter “Shutter”	23
3.4.1.4 Function parameter “Alarm”	25
3.4.1.5 Function parameter “Percentage”	27
3.4.1.6 Function parameter “Sequence”	28
3.4.1.7 Function parameter “Scene”	30
3.4.1.8 Function parameter “String”	32
3.5 Function parameter “Logical function E”	33
4-Communication objects description	35
4.1 Objects “General”	35
4.2 All objects with Logical function “N”	36
4.2.1 Objects “Master mode”	36
4.2.2 Objects “External telegram”	36
4.2.3 Objects “Switching”	37
4.2.4 Objects “Absolute Dimming”	37
4.2.5 Objects “Shutter”	37
4.2.6 Objects “Alarm”	38

4.2.7 Objects “Percentage”	38
4.2.8 Objects “Sequence”	38
4.2.9 Objects “Scene”	38
4.2.10 Objects “String(14 Byte)”	39
5-Application	40
5.1 Program functions diagram	40

1-General

HDL KNX / EIB series products of Multi function Motion Sensor is developed by HDL. Using KNX/EIB BUS communicate with other KNX devices. Database need to be downloaded to the presence detector by using ETS2 V1.3/ETS 3.0, The document describe how to use the products. Our products use standard according to EMC, electrical safety, environmental conditions.

The presence detectors are used to control objects, such as:

- * **Lighting**
- * **Motor**
- * **Shutter**
- * **Alarm**
- * **Other Equipments**

The rights and the copyright to this manual are exclusively the property of HDL.

1.1-Product Function

The multi function Movement detect sensor, embedded with function of temperature detecting, LUX detecting, two dry contact detecting and external telegram input via bus.

They assembled into five logic function blocks, each with ten output object. The presence detector can also report movement, temperature, brightness or dry contacts current status. This function is selected by user.

The following functions can be set individually for five logical block output object:

- * Switching
- * Absolute dimming
- * Shutter
- * Alarm
- * Percentage
- * Sequence
- * Scene
- * String(14bytes)

2- Hardware

The technical properties of HDL KNX/EIB Presence detector as the following sections.

2.1 Technical data

Presence detector

*Capture zone	110°
*Mounting height	2 ~ 4 m, ideally 2.50 m
*Range(mounting height 2.50m,+22°C)	approx. 6 m
*Brightness value	0 ~ 3000 lux

Power supply

*Operating voltage(supply by the bus)	21 ~ 30 V DC,
* Current consumption EIB / KNX(operate)	< 15 mA
* Current consumption EIB / KNX(standby)	< 5 mA
* Power consumption EIB / KNX(operate)	< 450 mW
* Power consumption EIB / KNX(standby)	< 150 mW

Connections

* EIB / KNX	Bus Connection Terminal 0.8 mm Ø, single core
-------------	--

Operating and display

* EIB / KNX push button	For assignment of the physical address For indicating normal mode (LED Off) or addressing mode (LED On); it is automatically extinguished once the physical address has been transferred.
* Red LED (VE1)	
* Green LED (VE2)	No use.
* Red LED (VE3)	For indicating working mode (LED On) or idle mode (LED Off);

Temperature range

* Operation	- 5 °C ~ + 45 °C
* Storage	- 25 °C ~ + 55 °C
* Transport	- 25 °C ~ + 70 °C

Environment conditions

* humidity	max. 95 % Non-condensing
------------	--------------------------

Appearance design

* Dimensions (H x W x D)	80 x 80 x 30 mm
--------------------------	-----------------

Mounting position	installed on a solid and level surface
Material and Colour	Plastic, grey
Standard and Safety	Certificated
* LVD Standard	EN60669-2-1, EN60669-1
*EMC Standard	EN50090-2-2
CE mark	
* In accordance with the EMC guideline and low voltage guideline	
Pollutant	Comply with RoHS

Application table

Type	M/HS05.1
Max. number of communication objects	110
Max. number of group addresses	254
Max. number of associations	254

Note: The programming requires the EIB Software Tools ETS2 V1.3 or ETS3.0. If use ETS2 V1.3, then import "*.vd2". If use ETS3.0, then Import "*.vd3"

2.2 Dimension drawings

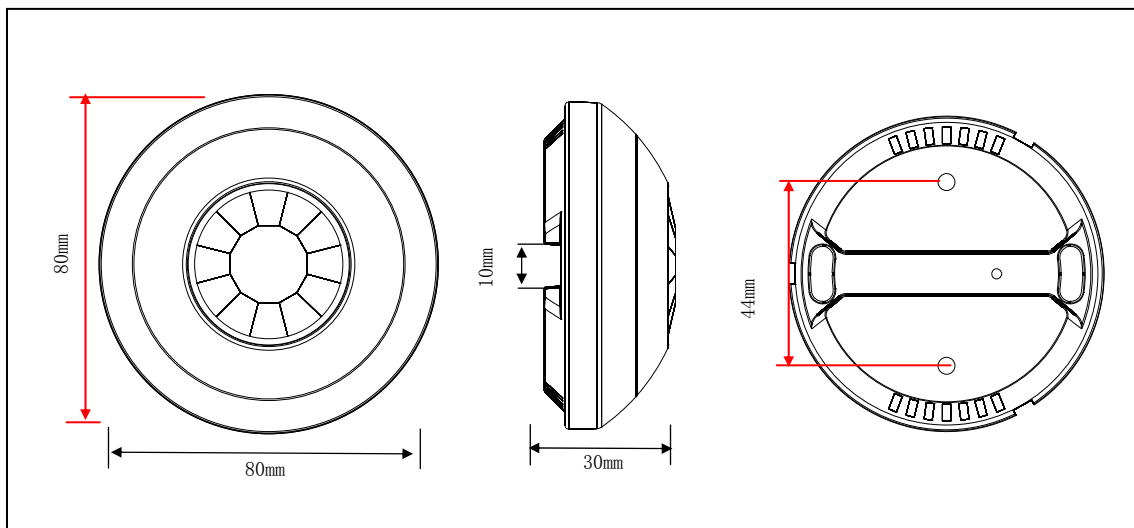

M/HS05.1

2.3 Wiring diagram

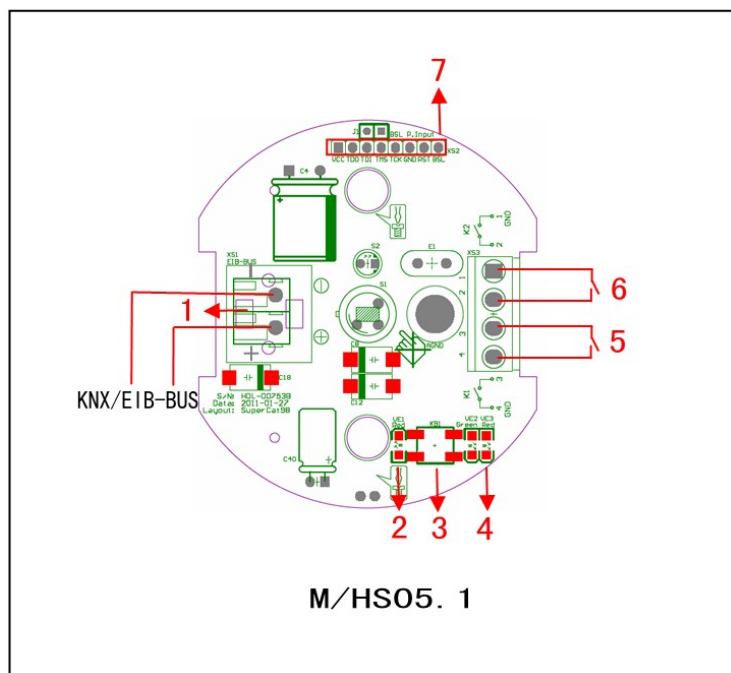

M/HS05. 1

- 1 KNX/EIB Bus Connector
- 2 Programming LED (VE1)
- 3 Programming button
- 4 Working LED (VE3)
- 5 Dry contact 1
- 6 Dry contact 2
- 7 Update

2.4 Range of Coverage

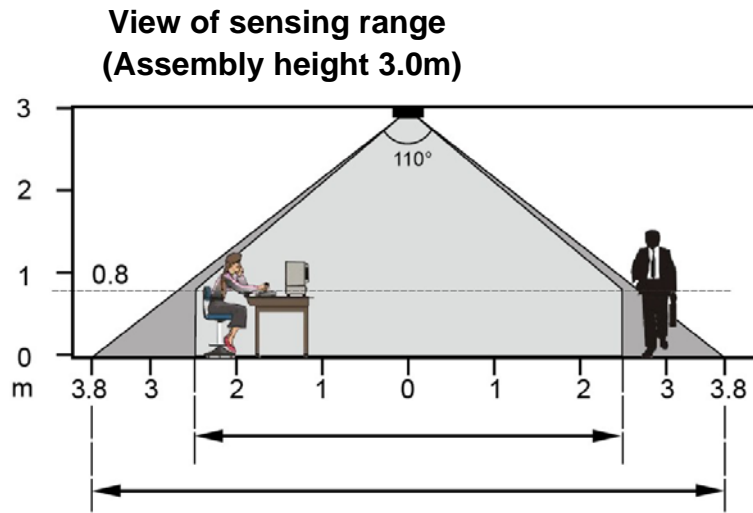

Side view of the sensing range

The circular sensing range for detecting people sitting and walking are different sizes. The recommended assembly height is 2 m – 3m. The sensitivity of the detector reduces as the assembly height increases. From assembly height of 3 m, walking movements are required and the edge areas of the sensing ranges of several detectors should overlap.

Room height (m)	Sensing range (m)	
	Sitting persons	Walking persons
2.0	approx. Φ 3	approx. Φ 5.0
2.5	approx. Φ 4	approx. Φ 6.5
3.0	approx. Φ 5	approx. Φ 7.5
3.5	- - -	approx. Φ 8.0

Table 1 of sensing range

- *The presence detector requires an unobstructed view of the persons to be detected.
- *Persons moving behind walls, even those made of glass, will not be sensed/detected.
- *The reception characteristics of the detector must be taken into account when selecting the assembly locations.

Sitting persons:

The specifications relate to the reduced sensing range for movements at table height (approx. 0.80m). The sensing sensitivity is reduced from an assembly height of >3m; stronger movements are required for clear sensing.

Walking persons:

Use of whole sensing range with small tolerance in edge area (+/- 0.5m).

2.5 Maintenance and Cautions

- *Please read this user manual carefully before any operation.
- *Don't close to the interfering devices.
- *The site should be ventilated with good cooling environment.
- *Pay attention to damp proof, quakeproof and dustproof.
- *Avoid rain, other liquids or caustic gas.
- *Please contact professional maintenance staff or HDL service center for repair or fix.
- *Remove the dust regularly and do not wipe the unit with the volatile liquids like alcohol, gasoline, etc.
- *If damaged by damp or liquid, turn off it immediately.
- *Regularly check the circuitry and other related circuit or cables and replace the disqualified circuitry on time.
- *For security, each circuit to connect an MCB or fuse
- *Installation location should be well-ventilated, pay attention to moisture, shock, dust proof.

3- Software

HDL KNX/EIB Presence detector database use ETS3.0 to do the design. The Interface and the functions Apply parameters please overview the following description of the paragraph.

The presence detector has five logical outputs, they are logical function A, logical function B, logical function C, logical function D and logical function E. Logical function E is determined by the other four.

Each output of the presence detector are independent and the same. So, Understand only one channel output is enough. The following paragraph will description of the logical function A output in detail.

3.1 Database functions Overview

The following table provide an overview of the functions and some parameters with the presence detector:

Sensor function	HS 5L Sensor
General	---
Delay after recover	Y
Sensor sensitivity	Y
Temperature compensation	Y
Brightness quiver	Y
Report movement state	Y
Report Lux value	Y
Report temperature value	Y
Report Dry contact 1 state	Y
Report Dry contact 2 state	Y
Logical function	---
Movement input and Single mode/Master mode	Y
Lux input	Y
Temperature input	Y
External telegram input via bus	Y
Dry contact 1 input	Y
Dry contact 2 input	Y
Logic	---
AND	Y
OR	Y

Block (outputs object)	---
Switching	Y
Absolute dimming	Y
Shutter	Y
Alarm	Y
Percentage	Y
Sequence	Y
Scene	Y
String	Y

Table 2: Database application overview.

3.2 Object/Association/Group address define

In following table, the objects are assigned to some function of the channel output pages, if active some functions and the object will be valid. One or more group addresses can be assigned to a object. The association will connect group addresses to the object.

Name	type	Max. number of communication objects	Max. number of associations	Max .number of group addresses
HS 5L Sesor	M/HS05.1	110	254	254

Table3: Overview the max. number of the objects, max. number of associations and max. number of the group addresses

Note: If you use ETS2V1.3, Please import “VD2”, But you use the ETS3.0, Please Import “VD3” to “VD5”.

3.3 Function parameter “General”

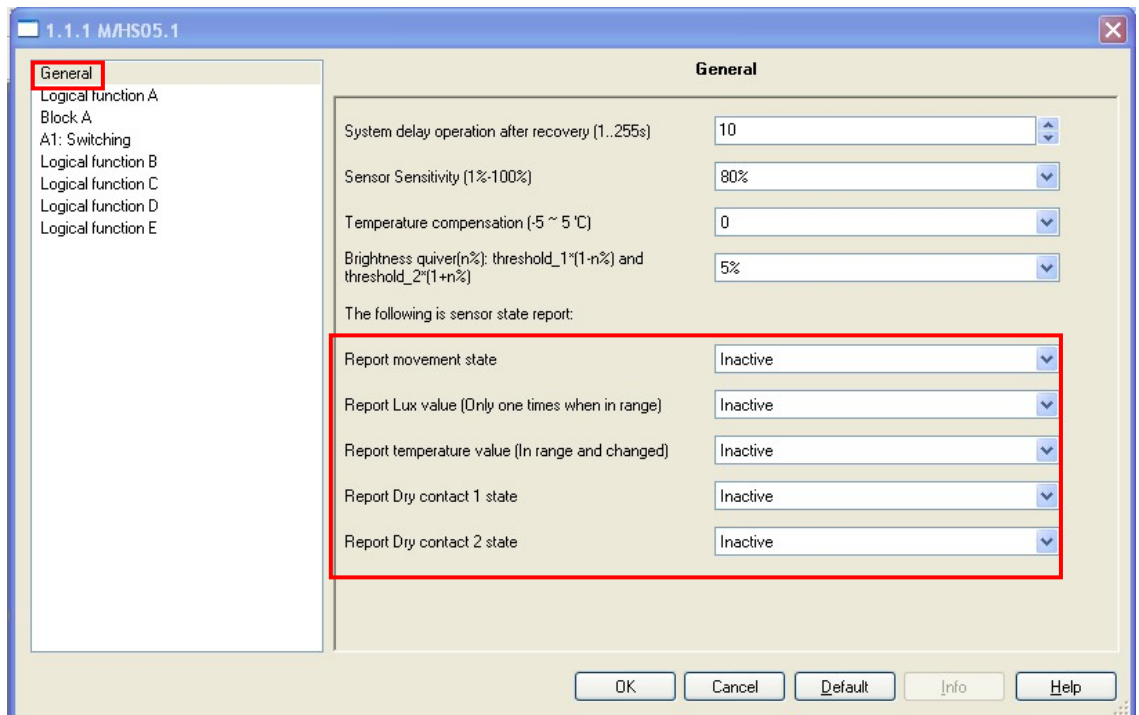

Fig1: “General” parameter windows

In the parameter of the general windows can setup some common functions.

---System delay operation after recovery (1.. 255s)

Can operate relay for a delay time 1..255s after the bus voltage recovery. The default value is 10 seconds. The Min. value is 1 second, and the max. value is 255 seconds.

Options: **1...255s**

When the bus voltage recovery and timer start, and when the time out, The presence detector can be allow operating. This function is selected by user.

---Sensor Sensitivity (1%~100%)

The range of the PIR sensitivity parameter is 1% to100%. The larger the value the more sensitive.

Options: **1%~100%**

The default value is 80%. If set too high possible interference (e.g 100%), and set too low may can't detect movement (e.g 1%).

---Temperature compensation (-5 ~ 5°C)

When the presence detector detects the temperature error, you can set the temperature compensation. The rang is -5 ~ 5°C. Set value 0 is not compensate.

---Brightness quiver(n%):threshold_1*(1-n%)and threshold_2*(1+n%)

Brightness within the effective range, when changes in the set range, the status does not change.

When the brightness within the effective range, the set range is in the between the value of the threshold_1*(1-n%) and threshold_2*(1+n%), Change the value of more than the range, the status will change.

When the brightness is not within the effective range, only the brightness changes to be effective within the value of threshold, the status will change.

- Options: **5%**
10%
15%
20%
25%
30%

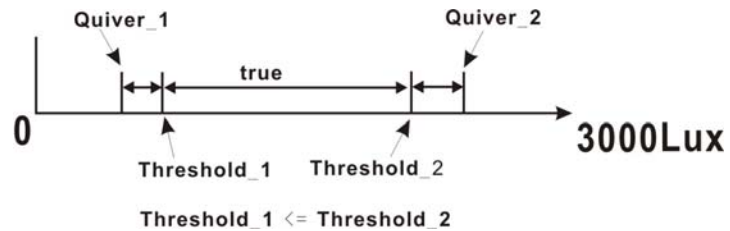

e.g. if Threshold_1 = 100 Lux and Threshold_2 = 300 Lux ,
 Quiver_1 = Threshold_1 * (1 - 5%) = 100 * (1 - 5%) = 95 Lux
 Quiver_2 = Threshold_2 * (1 + 5%) = 300 * (1 + 5%) = 315 Lux

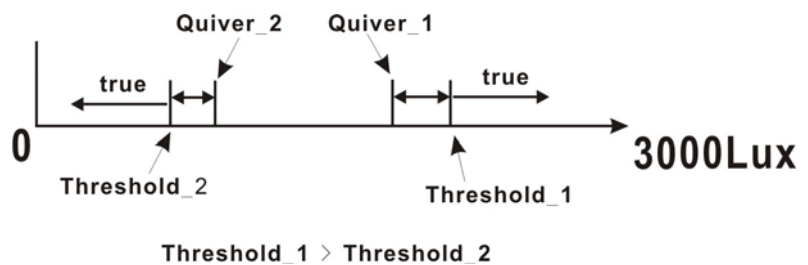

e.g. if Threshold_1 = 300 Lux and Threshold_2 = 100 Lux ,
 Quiver_1 = Threshold_1 * (1 - 5%) = 300 * (1 - 5%) = 285 Lux
 Quiver_2 = Threshold_2 * (1 + 5%) = 100 * (1 + 5%) = 105 Lux

---The following is sensor state report:

The sensor has five independent state report, and may, according to needs, set up is “Active”. If one set to “Active”, and then you can set the sensor’s conditions. Sending its current state when meet the conditions.

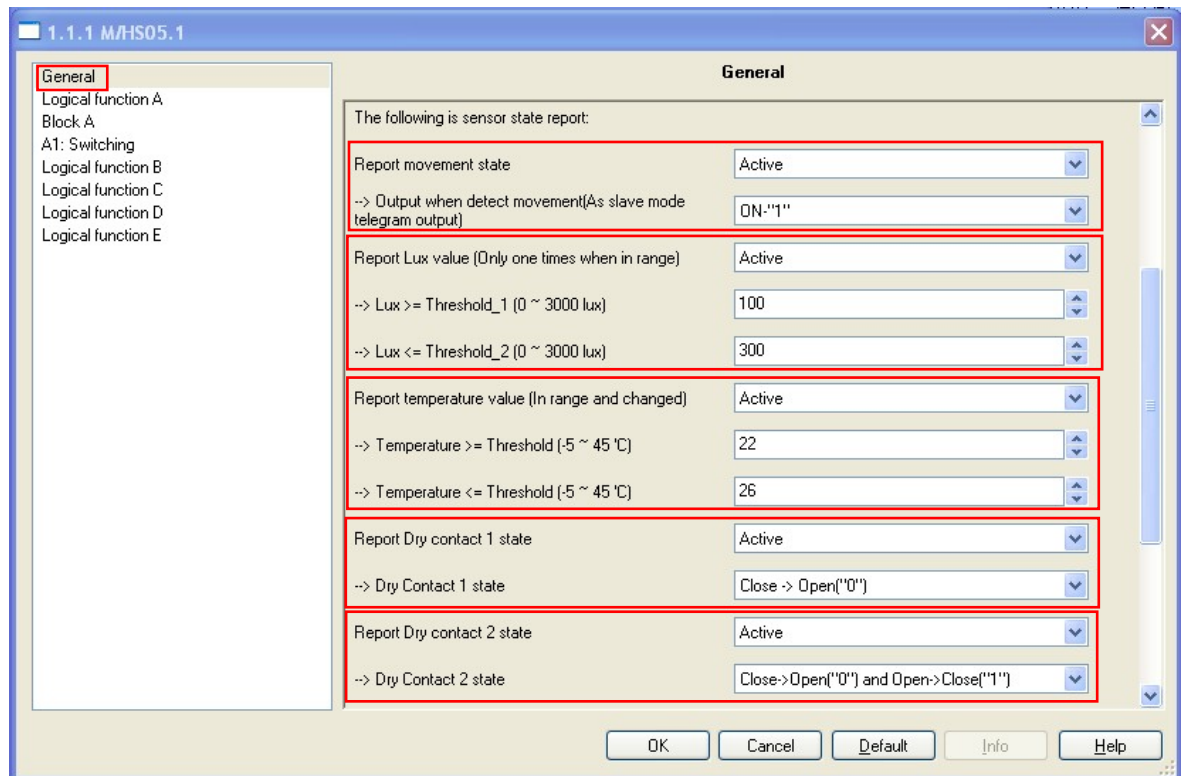

Fig1.1 : “General” parameter windows

---Report movement state

If the presence detector detects something in its detection zone. It will be report **OFF-“0”** or **ON -“1”** to the bus cycle (1 second), until dose not detect any more movement. This function is often used to slave mode.

---> **Output when detect movement (As slave mode telegram output)**

Options: **OFF-“0”**
ON -“1”

OFF-“0” : Report **OFF** to the bus when detected movement.

ON -“1”: Report **ON** to the bus when detected movement.

Master / Slave mode: It is possible to switch several presence detectors together. This is necessary e.g. in rooms in which one presence detector alone is no longer sufficient for the detection. If

two or more presence detectors are installed in a room, one presence detector must operate as “Master” and all the others must be set to the “Slave” function. In the “Slave” function, the presence detector only sends **OFF** or **ON** telegrams cyclically when it detects movement. The recovery time only runs for the master presence detector. The recovery time is restarted for the master after each **OFF** or **ON** telegram. To ensure that the presence detection of the master and slave is equal, the same group address must be used for both devices. If different group addresses are used, the recovery time in the master is restarted each time an **OFF** or **ON** telegram is received cyclically whereby the light is not switched on.

--- Report Lux value(Only one times when in rang)

If lux values into the valid range it will be report the current value to the bus only one times. However if it's in the setting of the range does not take the initiative to send the luminance values. But an external device can always read the current Lux values.

--> Lux >= Threshold_1(0~3000lux)

Options: **0~3000lux**

--> Lux <= Threshold_2(0~3000lux)

Options: **0~3000lux**

Set the rang of the Lux value,

If $\text{Threshold}_1 \leq \text{Threshold}_2$, the valid range is $\text{Threshold}_1 \leq \text{Lux} \leq \text{Threshold}_2$.

If $\text{Threshold}_1 > \text{Threshold}_2$, the valid range is $\text{Lux} \geq \text{Threshold}_1$ or $\text{Lux} \leq \text{Threshold}_2$.

--- Report temperature value (in rang and changed)

The temperature value is in the rang and changed , it will report the new temperature to the bus. And an external device can always read the current values.

--> Temperature >= Threshold(-5~45°C)

Options: **-5~45°C**

--> Temperature <= Threshold(-5~45°C)

Options: **-5~45°C**

Same as set the range of the Lux value.

--- Report Dry contact 1 state

It will be send the dry contact 1 state to the bus.

Options: **Close - > Open (“0”)**

Open - > Close (“1”)

Close - > Open (“0”) and Open -> Close (“1”)

Close - > Open (“0”): when the dry contact 1 state changed from close to open, the state will be send **Open(“0”)** telegrams to the bus.

Open -> Close (“1”): when the dry contact 1 state changed from open to close, the state will be send **Close (“1”)** telegrams to the bus.

Close - > Open (“0”) and Open -> Close (“1”): as long as the dry contact 1 state changed, the state will be send to the bus.

--- Report Dry contact 2 state

Same as dry contact 1.

3.4 Function parameter “Logical function A”

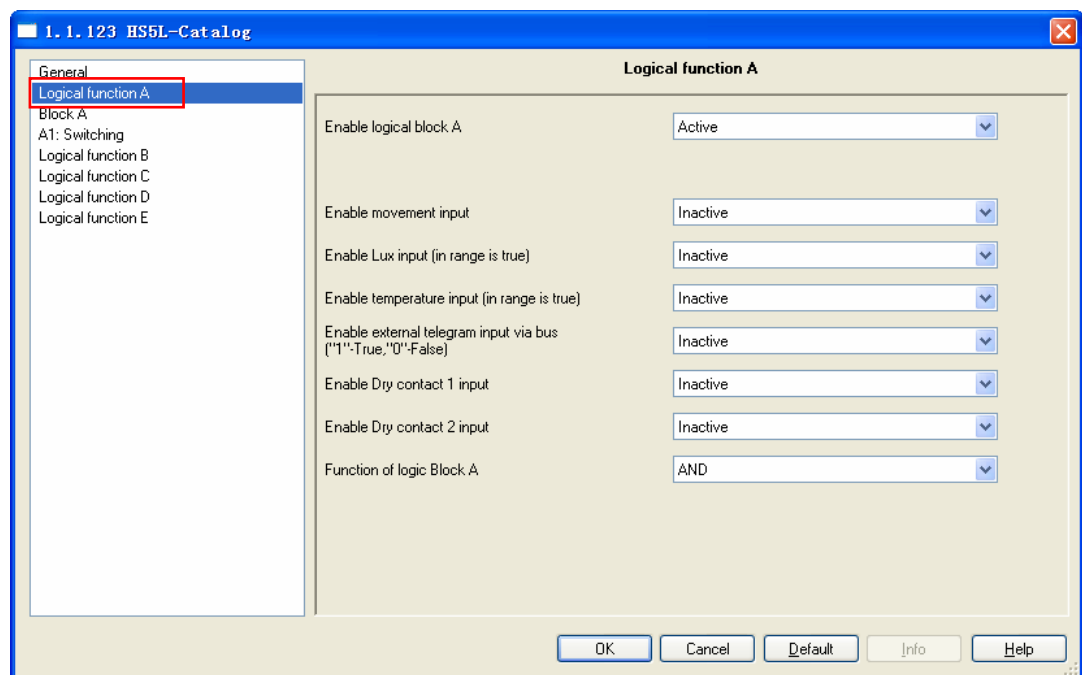
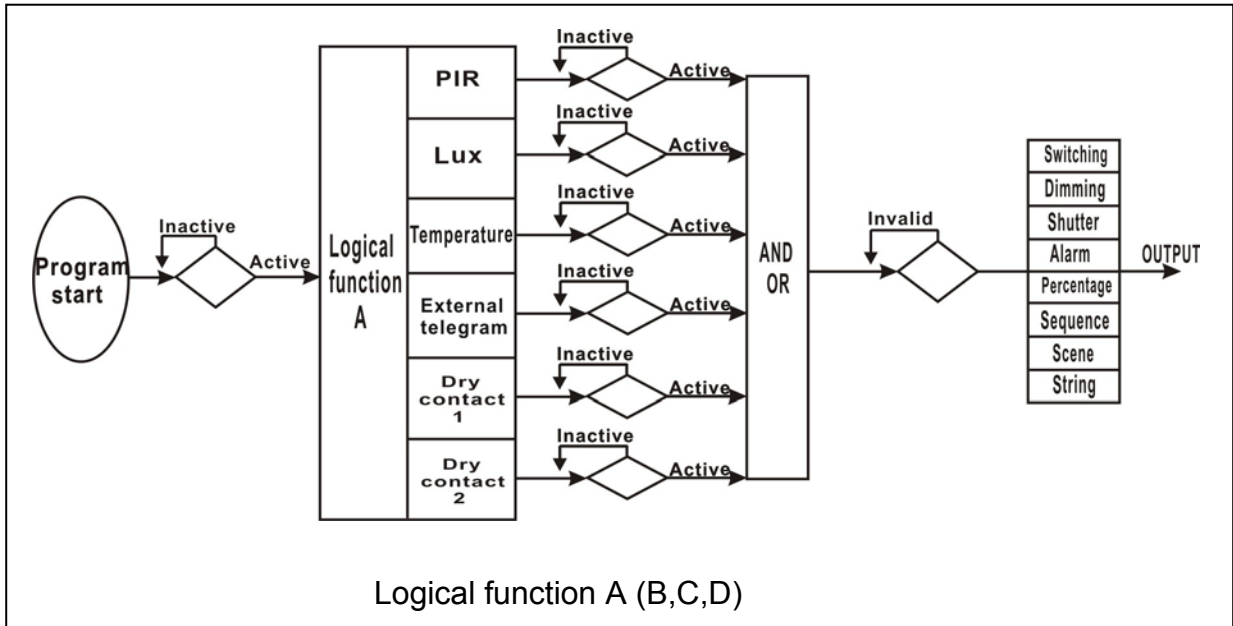

Fig2: “Logical function A” parameter windows

Set input conditions of logic A, the logical is true when the conditions reached.



---Enable logical block A

Set the enable of logical block A.

Options: **Inactive**

Active

Inactive: Disable Logic function A.

Active: Enable Logic function A.

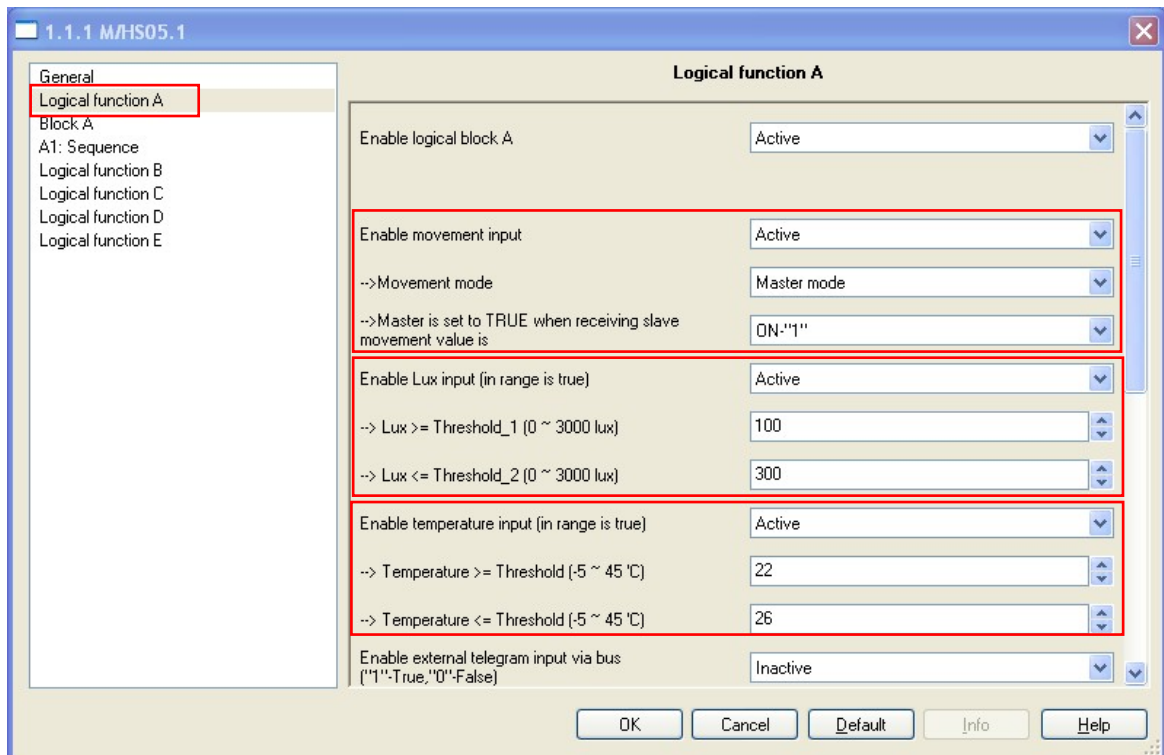

Fig2.1: “Logical function A” parameter windows
Set conditions of logical function A.

---Enable movement input

Options: **Inactive**
Active

Enable movement standard mode.

-->Movement mode

Options: **Inactive**
Active

-->Master is set to TRUE when receiving slave movement value is

Options: **OFF-“0”**
ON-“1”

OFF-“0”: when receiving slave movement value is **OFF-“0”** the conditions reached

ON-“1”: when receiving slave movement value is **ON-“1”** the conditions reached

---Enable Lux input(in range is true)

-->Lux >= Threshold_1(0~3000lux)

Options: 0~3000 lux

-->Lux <= Threshold_2(0~3000lux)

Options: 0~3000 lux

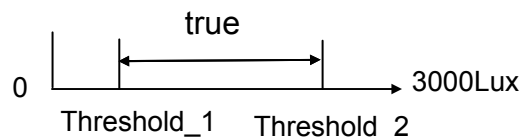

Threshold_1 <= Threshold_2

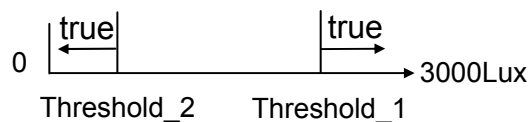

Threshold_1 > Threshold_2

---Enable temperature input (in range is true)

When the temperature is in the range then reached the condition.

--> Temperature >= Threshold (-5~45°C)

Options: -5~45°C

--> **Temperature<= Threshold (-5~45°C)**

Options: -5~45°C

Set the temperature's range.

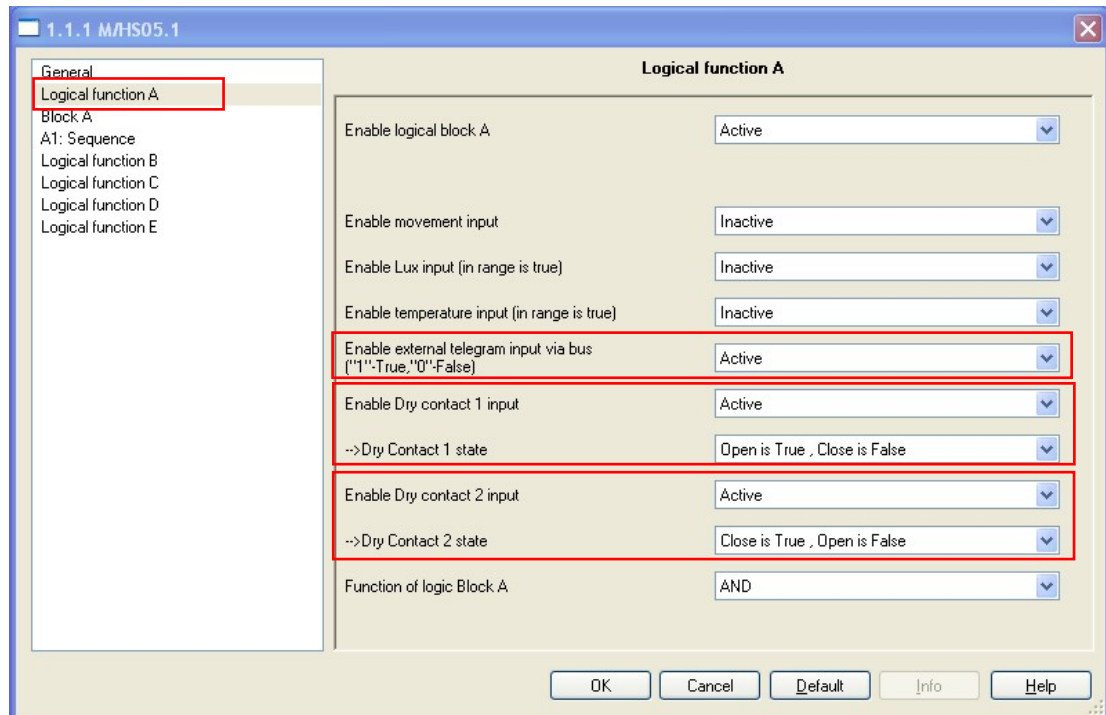

Fig2.2: “Logical function A” parameter windows

---Enable external telegram input via bus(“1” -true, “0”-False)

The condition was reached by value “1” -true of receiving telegram;

The condition wasn't reached by value “0” -False of receiving telegram.

Options: **Inactive**

Active

The value will be saved in the EEPROM, until it is change.

---Enable Dry contact 1 input

Set the enable of the contact 1.

Options: **Inactive**

Active

Inactive: if you select the inactive, Disable Dry contact 1 input.

-->Dry Contact 1 state

Options: **Close is True, Open is False**

Open is True, Close is False

Close is True, Open is False: when dry contact 1 close, the condition is reached.

Open is True, Close is False: when dry contact 1 open, the condition is reached.

---Enable Dry contact 2 input

Same as dry contact 1 input.

---Function of logic Block A

Options: **AND**

OR

AND: Boolean calculation according to “AND” rule. All conditions are reached then will to turn “Block A”’s targets.

OR: Boolean calculation according to “OR” rule .As long as there is a condition to reached then will to turn “Block A”’s targets.

3.4.1 Function parameter “Block A”

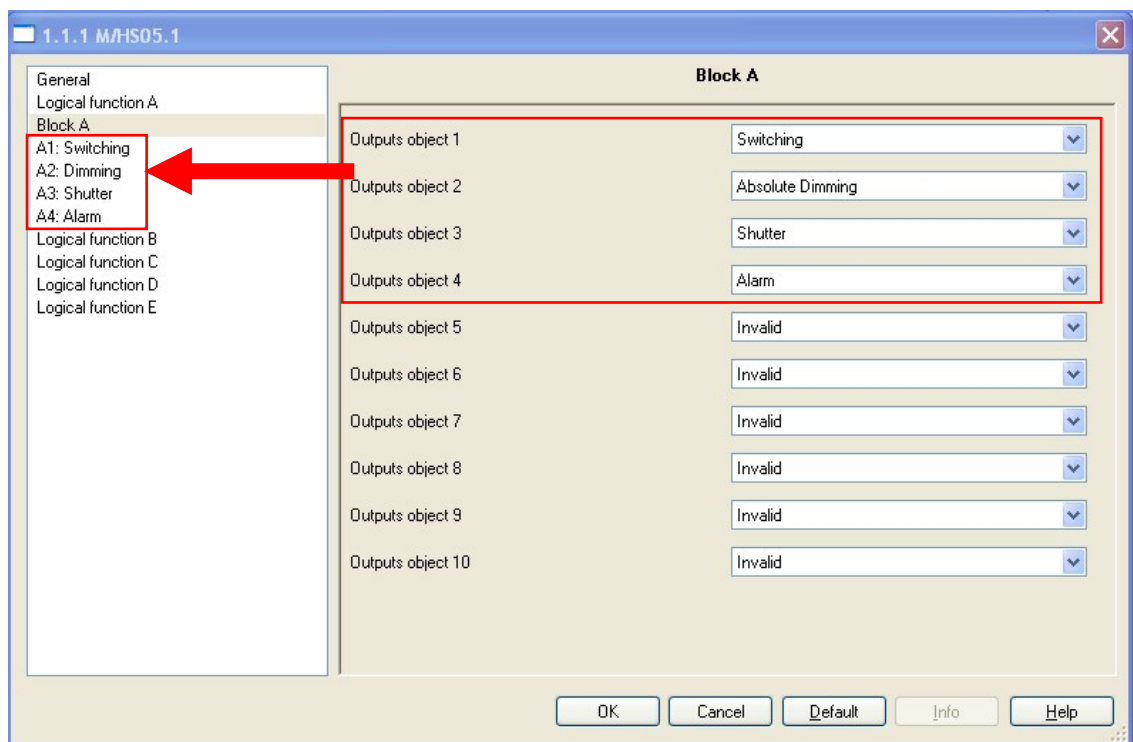

Fig3: “Block A” parameter window

In the parameter windows of the “Block A”, can setup logic A’s output targets. A total of 10 targets and 9 types can be set.

---Outputs object 1

Options: **Invalid**

Switching

Absolute Dimming

Shutter
Alarm
Percentage
Sequence
Scene
String(14 byte)

3.4.1.1 Function parameter “Switching”

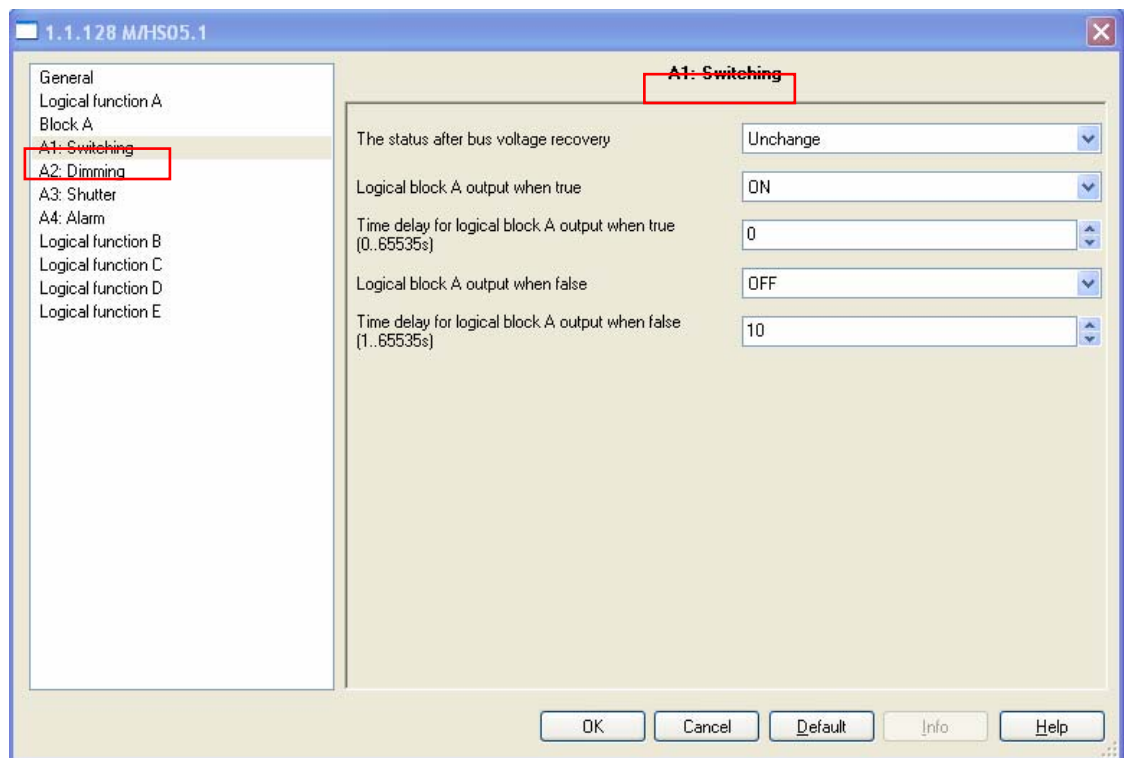

Fig3.1: “Switching” parameter window

In the parameter windows of the “Switching”, can setup switching functions. Through functional selection and download the database to the device, and device will work in accordance with the selected function.

---The status after bus voltage recovery

Options: **Unchange**
OFF
ON
Recovery

Unchanged: Switching no output after bus voltage recovery.

OFF: Switching will send **OFF** telegram after the bus voltage recovery.

ON: Switching will send **ON** telegram after the bus voltage recovery.

Recovery: After bus voltage recovery, switching will send **OFF** or **ON** telegram back to the state of the power-down previous.

---Logical block A output when true

When options all reached the logical block A's output.

Options: **Invalid**

OFF

ON

Invalid: Switching no output when logical block A is true.

OFF: Switching output **OFF** telegram when logical block A is true.

ON: Switching output **ON** telegram when logical block A is true.

---Time delay for logical block A output when true(0..65535s)

Options: **0..65535s**

Set the output of the delay time when the logical is true. The range is 0..65535s.

---Logical block A output when false

Options: **Invalid**

OFF

ON

Invalid: Switching no output when logical block A is false.

OFF: Switching output **OFF** telegram when logical block A is false.

ON: Switching output **ON** telegram when logical block A is false.

---Time delay for logical block A output when false (1..65535s)

Options: **1..65535s**

Set the output of the delay time when the logical is false. The range is 1..65535s.

3.4.1.2 Function parameter “Dimming”

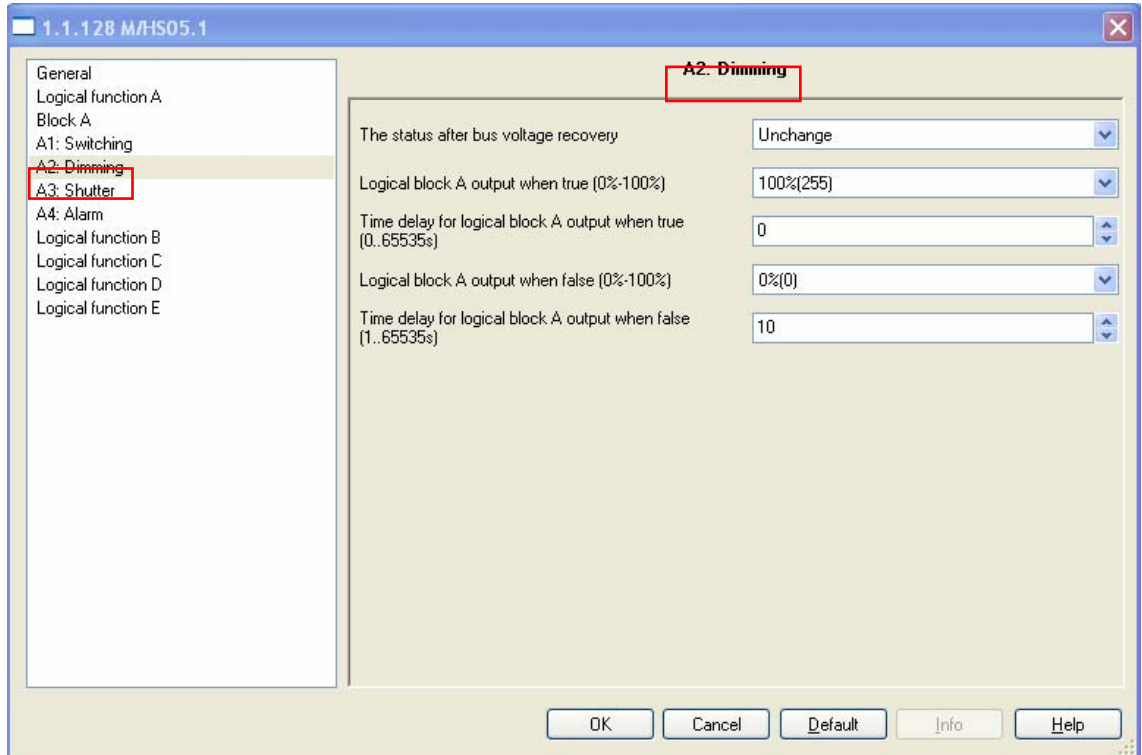

Fig3.2: “Dimming” parameter window

---The status after bus voltage recovery

Options: **Unchange**

0%(0)

100%(255)

Recovery

Unchanged: The brightness unchanged after bus voltage recovery.

0%(0): Dimming will send **0%(0)** telegram after the bus voltage recovery.

100%(255): Dimming will send **100%(255)** telegram after the

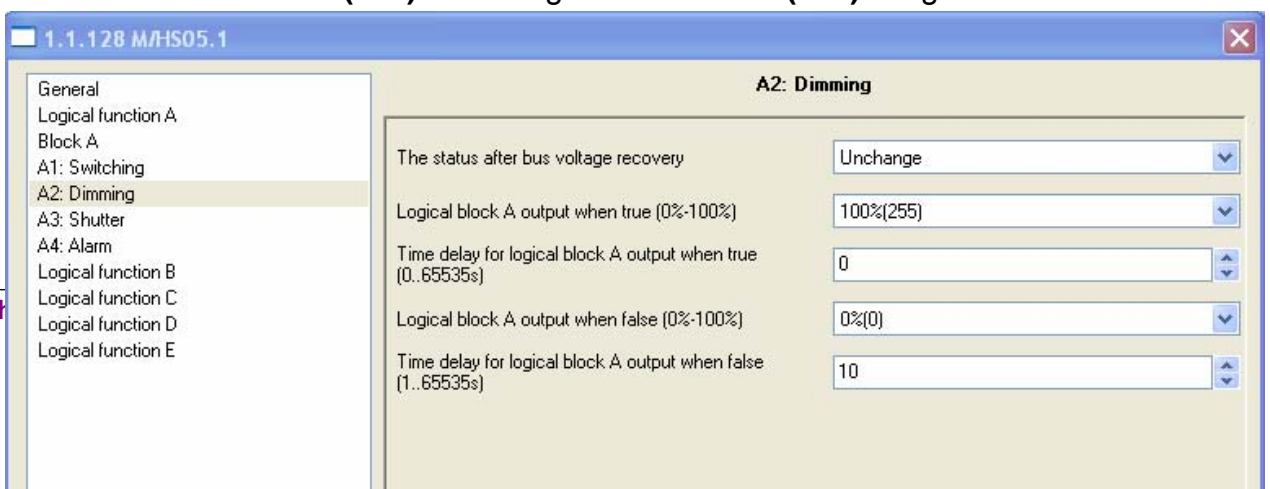

Options: **0%(0)-100%(255)**

0%(0) is dark, 100%(255) is the brightest brightness.

---Time delay for logical block A output when true(0..65535s)

Options: **0..65535s**

Set the output of the delay time when the logical is true. The range is 0..65535s

---Logical block A output when false (0%-100%)

Options: **0%(0)-100%(255)**

Set the output brightness when the logical is false.

---Time delay for logical block A output when false (1..65535s)

Options: **1..65535s**

Set the output of the delay time when the logical is false. The range is 1..65535s.

3.4.1.3 Function parameter “Shutter”

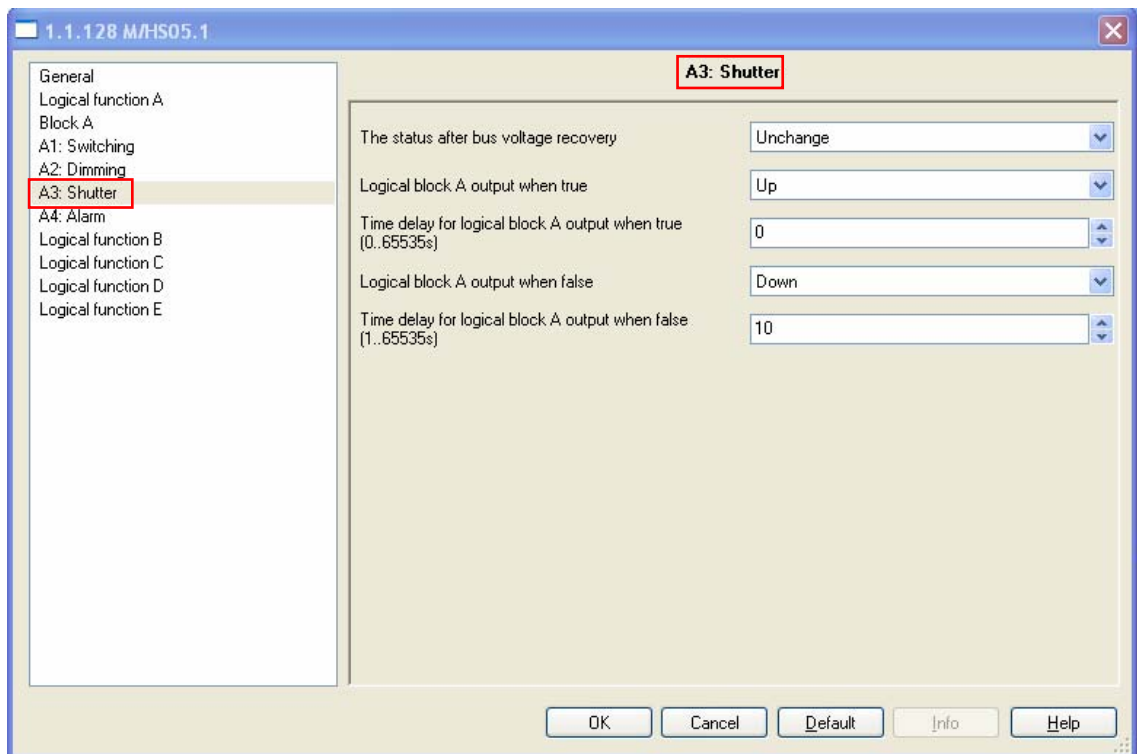

Fig3.3: “Shutter” parameter window
---The status after bus voltage recovery

Options: **Unchange**
Up
Down
Recovery

Unchanged: Shutter status unchanged after bus voltage recovery.

Up: Shutter will send **Up** telegram after the bus voltage

Down: Shutter will send **Down** telegram after the bus voltage

Recovery: After bus voltage recovery, shutter status will be back to the state of the power-down previous.

---Logical block A output when true

Set the output state of the shutter when the logical is true.

Options: **Invalid**
Up
Down

Invalid: Shutter no output when logical block A is true.

Up: Shutter output **Up** telegram when logical block A is true.

Down: Shutter output **Down** telegram when logical block A is true.

---Time delay for logical block A output when true (0..65535s)

Options: **0..65535s**

Set the output of the delay time when the logical is true. The range is 0..65535s.

---Logical block A output when false

Set the output state of the shutter when the logical is false.

Options: **Invalid**
Up
Down

Invalid: Shutter no output when logical block A is false.

Up: Shutter output **Up** telegram when logical block A is false.

Down: Shutter output **Down** telegram when logical block A is false..

---Time delay for logical block A output when false (1..65535s)

Options: **1..65535s**

Set the output of the delay time when the logical is false. The range is 1..65535s.

3.4.1.4 Function parameter “Alarm”

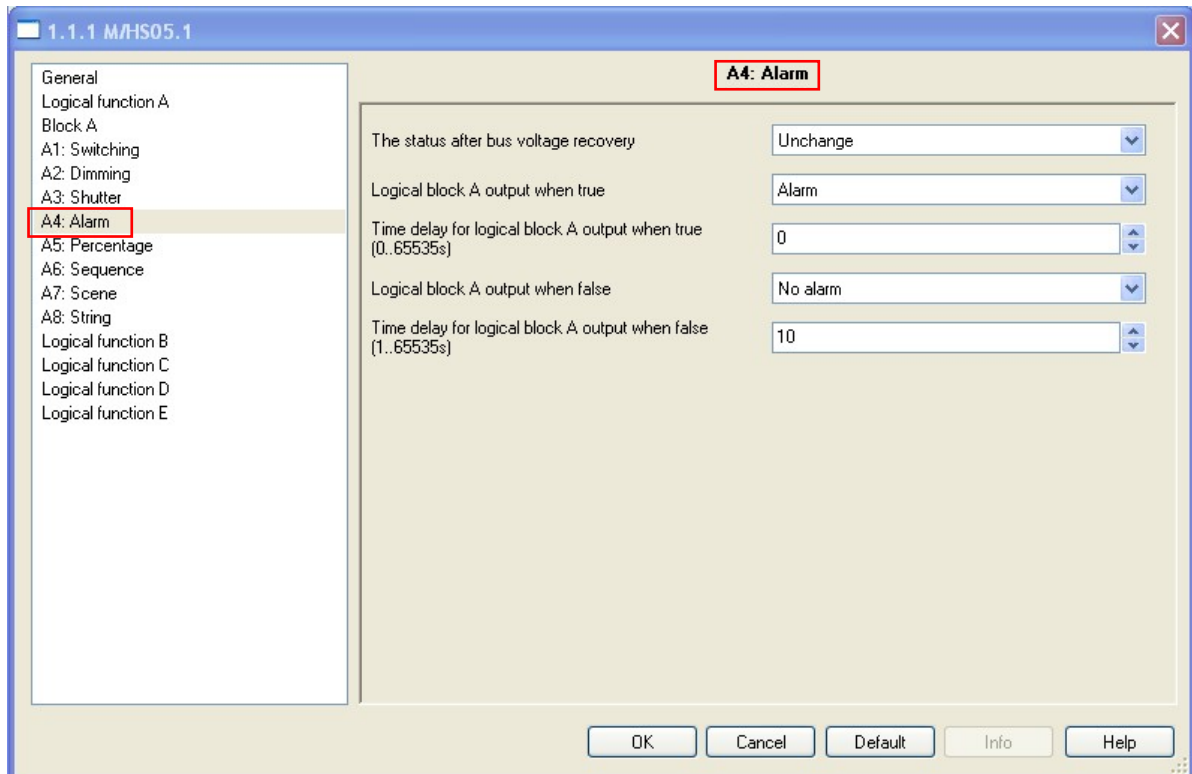

Fig3.4: “Alarm” parameter window

---The status after bus voltage recovery

Options: **Unchange**

No alarm

Alarm

Recovery

Unchanged: Alarm status unchanged after bus voltage recovery.

No alarm: Alarm will send **No alarm** telegram after the bus voltage

Alarm: Alarm will send **Alarm** telegram after the bus voltage

Recovery: After bus voltage recovery, alarm status will be back to the state of the power-down previous.

---Logical block A output when true

Set the output state of the alarm when the logical is true.

Options: **Invalid**

No alarm

Alarm

Invalid: Alarm no output when logical block A is true.

No alarm: Alarm output **No alarm** telegram when logical block A is true.

Alarm: Alarm output **Alarm** telegram when logical block A is true.

---Time delay for logical block A output when true (0..65535s)

Options: **0..65535s**

Set the output of the delay time when the logical is true. The range is 0..65535s.

---Logical block A output when false

Set the output state of the alarm when the logical is false.

Options: **Invalid**

No alarm

Alarm

Invalid: Alarm no output when logical block A is false.

No alarm: Alarm output **No alarm** telegram when logical block A is false.

Alarm: Alarm output **Alarm** telegram when logical block A is false..

---Time delay for logical block A output when false (1..65535s)

Options: **1..65535s**

Set the output of the delay time when the logical is false. The range is 1..65535s.

3.4.1.5 Function parameter “Percentage”

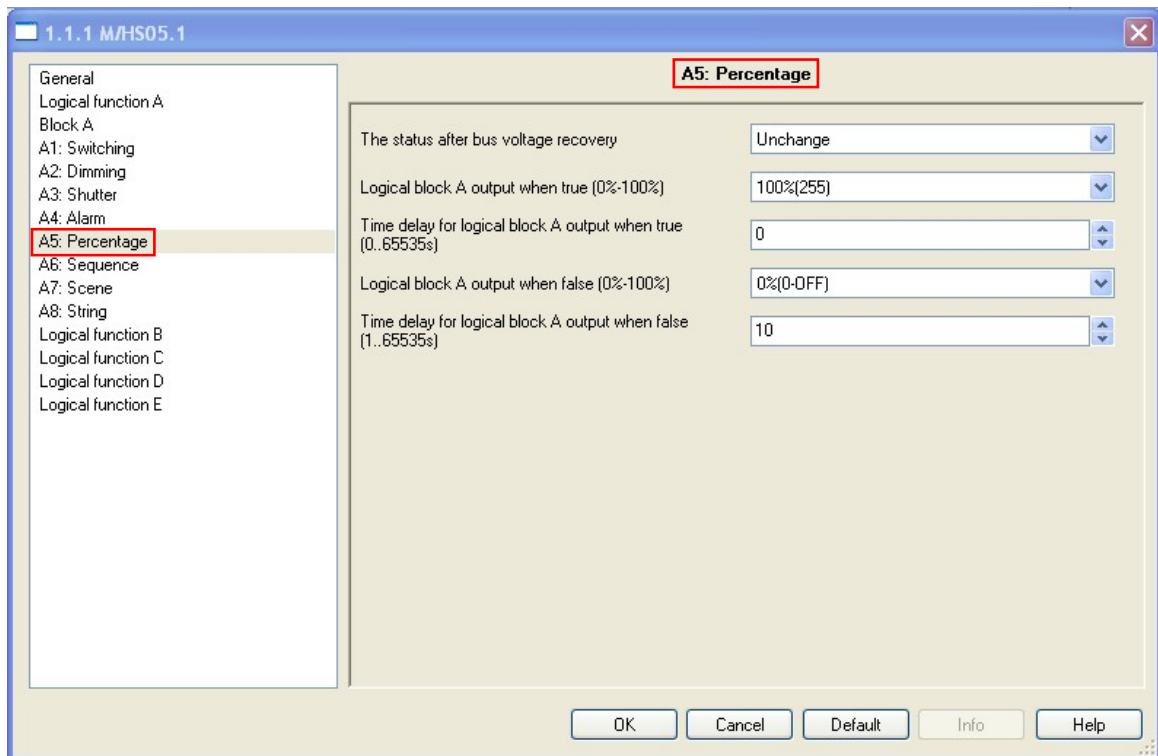

Fig3.5: “Percentage” parameter window

---The status after bus voltage recovery

Options: **Unchange**

0%(0)

100%(255)

Recovery

Unchanged: Percentage unchanged after bus voltage recovery.

0%(0): Percentage will send **0%(0)** telegram after the bus voltage recovery.

100%(255): Percentage e will send **100%(255)** telegram after the bus voltage recovery.

Recovery: After bus voltage recovery, percentage will be back to the state of the power-down previous.

---Logical block A output when true (0%-100%)

Set the output percentage when the logical is true.

Options: **0%(0)-100%(255)**

0%(0) is dark, 100%(255) is the brightest brightness.

---Time delay for logical block A output when true(0..65535s)

Options: **0..65535s**

Set the output of the delay time when the logical is true. The range is 0..65535s.

---Logical block A output when false (0%-100%)

Options: **0%(0)-100%(255)**

Set the output percentage when the logical is false.

---Time delay for logical block A output when false (1..65535s)

Options: **1..65535s**

Set the output of the delay time when the logical is false. The range is 1..65535s.

3.4.1.6 Function parameter “Sequence”

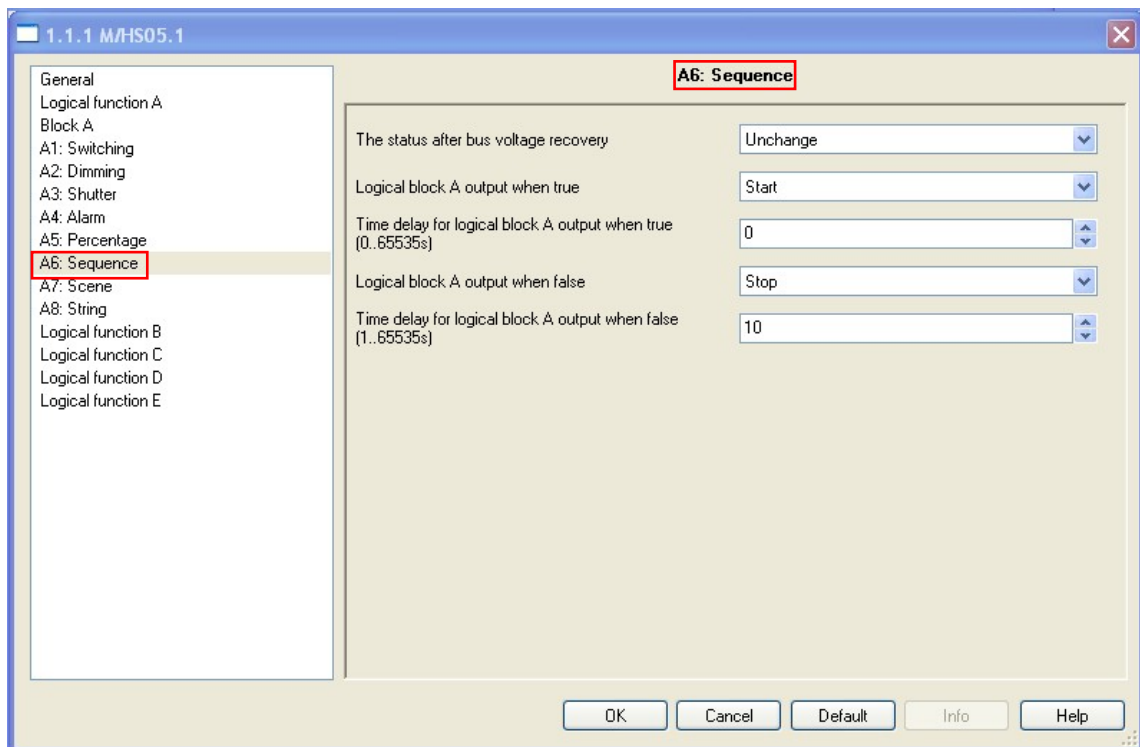

**Fig3.6: “Sequence” parameter window
---The status after bus voltage recovery**

Options: **Unchange**
Stop
Start
Recovery

Unchanged: Sequence unchanged after bus voltage recovery.

Stop: Sequence will send **Stop** telegram after the bus voltage recovery.

Start: Sequence will send **Start** telegram after the bus voltage recovery.

Recovery: After bus voltage recovery, Sequence will send **Stop** or **Start** telegram back to the state of the power-down previous.

---Logical block A output when true

Set the output state of the Sequence when the logical is true.

Options: **Invalid**
Stop
Start

Invalid: Sequence no output when logical block A is true.

Stop: Sequence output **Stop** telegram when logical block A is true.

Start: Sequence output **Start** telegram when logical block A is true.

---Time delay for logical block A output when true (0..65535s)

Options: **0..65535s**

Set the output of the delay time when the logical is true. The range is 0..65535s.

---Logical block A output when false

Set the output state of the Sequence when the logical is false.

Options: **Invalid**
Stop
Start

Disable: Sequence no output when logical block A is false.

Stop: Sequence output **Stop** telegram when logical block A is false.

Start: Sequence output **Start** telegram when logical block A is false.

---Time delay for logical block A output when false (1..65535s)

Options: 1..65535s

Set the output of the delay time when the logical is false. The range is 1..65535s.

3.4.1.7 Function parameter “Scene”

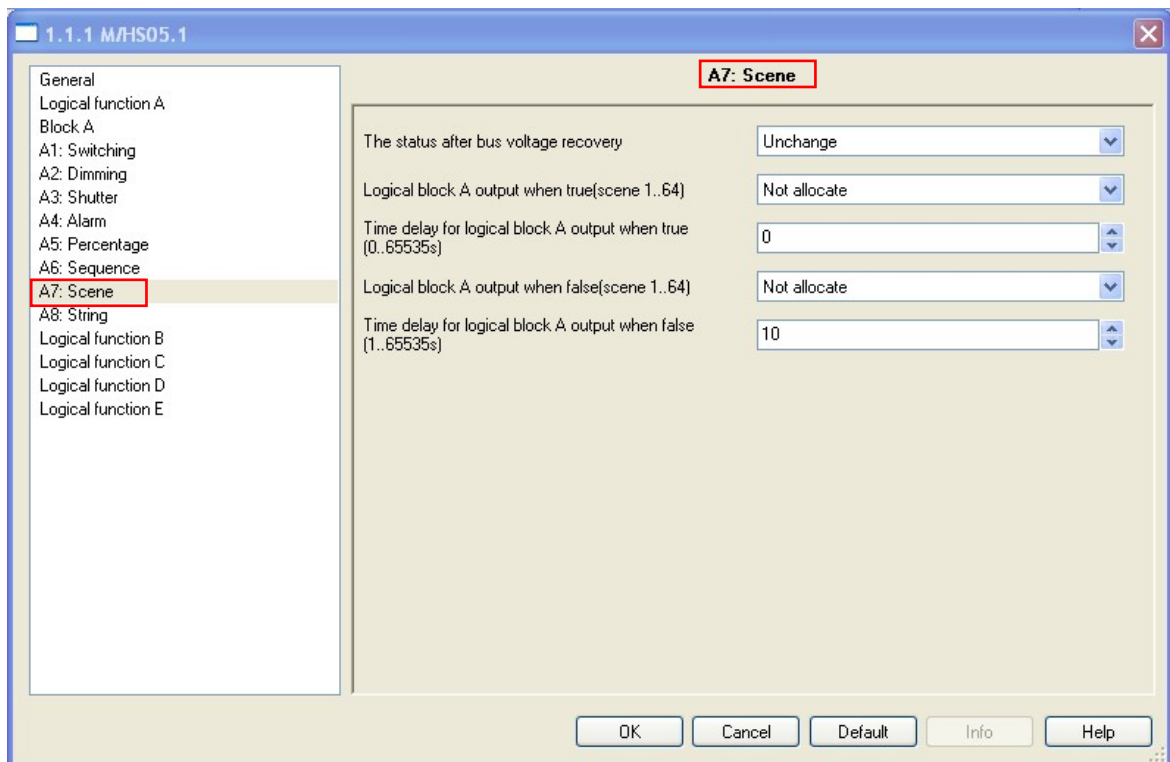

Fig3.7: “Scene” parameter window
Set the parameters of the scene.

---The status after bus voltage recovery

Options: **Unchange**

Logical block A output when true

Logical block A output when false

Recovery

Unchanged: Scene status unchanged after bus voltage recovery.

Logical block A output when true: Scene will send **Logical block A output when true** 's scene NO. after the bus voltage recovery.

Logical block A output when false: Scene will send **Logical block A output when false** 's scene NO. after the bus voltage recovery.

Recovery: After bus voltage recovery, scene will be send scene NO. back to the state of the power-down previous.

---Logical block A output when true(scene 1...64)

Set the output state of the scene when the logical is true.

Options: **Not allocate**

Scene NO.01

...

Scene NO.64

Not allocate: No output when the logical is true.

Scene NO.01...Scene NO.64: Output the specified scene when the logical is true.

Scene number is between 1 and 64, the value is between 0 and 63 or not allocate.

---Time delay for logical block A output when true (0..65535s)

Options: **0..65535s**

Set the output of the delay time when the logical is true. The range is 0..65535s.

---Logical block A output when false

Set the output state of the scene when the logical is false.

Options: **Not allocate**

Scene NO.01

...

Scene NO.64

Not allocate: No output when the logical is false.

Scene NO.01...Scene NO.64: Output the specified scene when the logical is false.

---Time delay for logical block A output when false (1..65535s)

Options: **1..65535s**

Set the output of the delay time when the logical is false. The range is 1..65535s.

3.4.1.8 Function parameter “String”

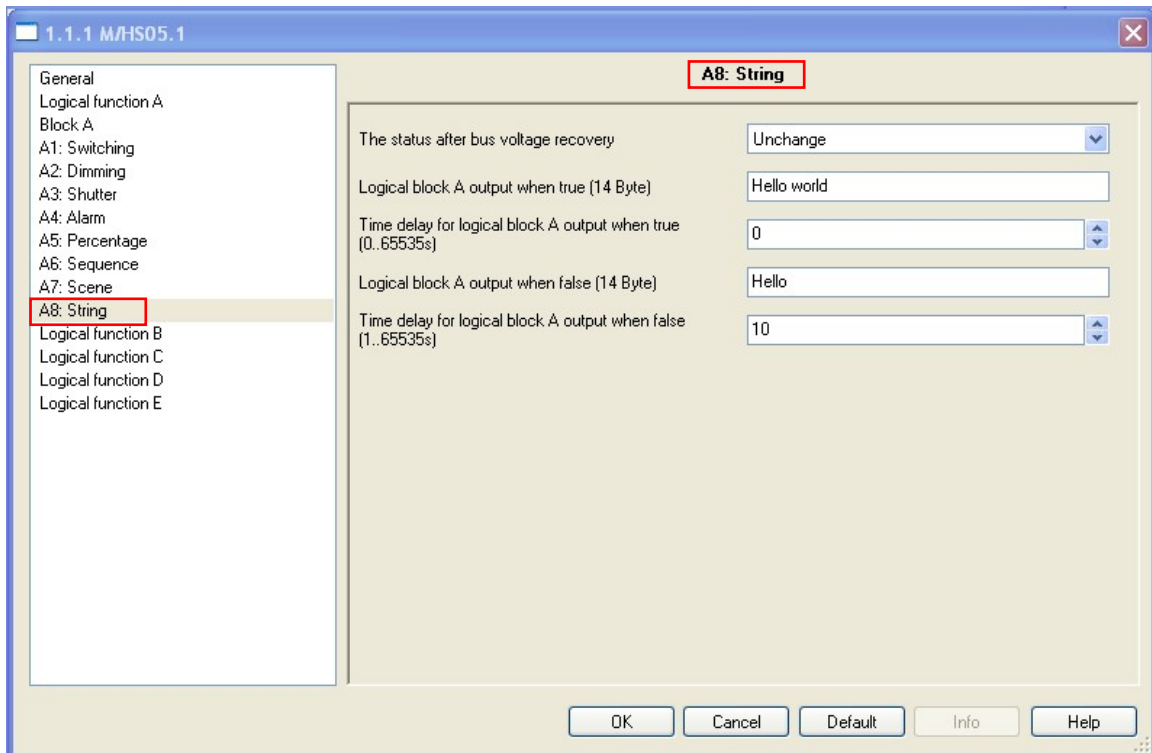

Fig3.8: “String” parameter window

Set the parameters of the string.

---**The status after bus voltage recovery**

Options: **Unchange**

Logical block A output when true

Logical block A output when false

Recovery

Unchanged: String status unchanged after bus voltage recovery.

Logical block A output when true: String will send **Logical block A output when true** 's string after the bus voltage recovery.

Logical block A output when false: String will send **Logical block A output when false** 's string after the bus voltage recovery.

Recovery: After bus voltage recovery, string will be back to the state of the power-down previous.

---Logical block A output when true (14 Byte)

Set the output string when the logical is true. A total of 14 byte can be set

---Time delay for logical block A output when true (0..65535s)

Options: **0..65535s**

Set the output of the delay time when the logical is true. The range is 0..65535s.

---Logical block A output when false

Set the output string when the logical is false. A total of 14 byte can be set

---Time delay for logical block A output when false (1..65535s)

Options: **1..65535s**

Set the output of the delay time when the logical is false. The range is 1..65535s.

3.5 Function parameter “Logical function E”

Fig4: “Logical function E” parameter window

Logical function E is decided by the logical A, logical B, logical C and logical D's condition,

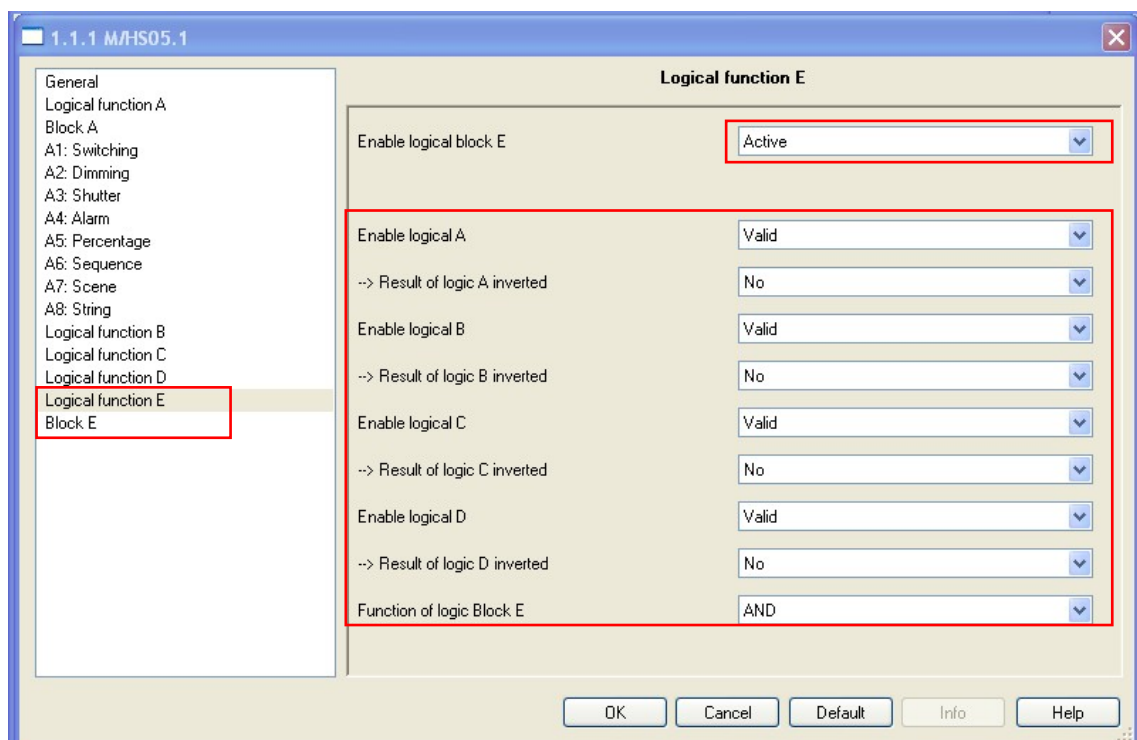
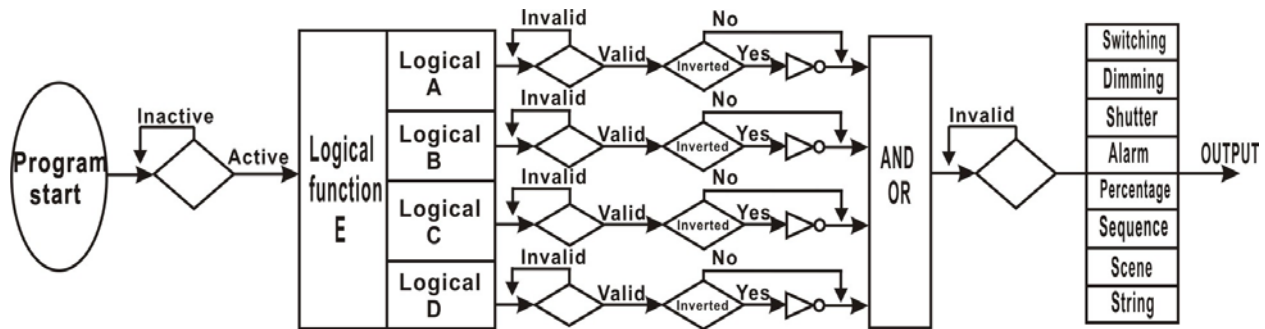

Fig4.1: “Logical function E” relationship

---Enable logical A

If **logical A** as a condition of input logic E, then must enable **logical function A**.

Options: **Invalid**
Valid

Invalid: Invalid Logic function A as a condition of input logic E

Valid: Valid Logic function A as a condition of input logic E

--> Result of logic A inverted

Options: **No**
Yes

No: Logic function A results non Inverted.

Yes: Logic function A results Inverted.

Note: Movement input must be “Inactive” when logic A inverted option selected to “YES”. Reference **Fig2.1**

---Enable logical B

Same as **Enable logical A**.

---Enable logical C

Same as **Enable logical A**.

---Enable logical D

Same as **Enable logical A**.

---Function of logic Block E

Options: **AND**
OR

AND: Boolean calculation according to “AND” rule. All conditions are reached then will to turn “Block E”’s targets.

OR: Boolean calculation according to “OR” rule .As long as there is a condition to reached then will to turn “Block E”’s targets.

4-Communication objects description

In this section will introduce the communication objects, The objects will show by setting the function enable .

Note: In following sections the **N=A,B,C,D,E** and the **n=1,2,3,4,5,6,7,8,9,10**

4.1 Objects “General”

Number	Name	Object Function	Description	Group Addresses	Length	C	R	W	T	U
0	General	Movement state			1 bit	C	R	-	T	-
1	General	Brightness value			2 Byte	C	R	-	T	-
2	General	Temperature value			2 Byte	C	R	-	T	-
3	General	Dry contact 1 state			1 bit	C	R	-	T	-
4	General	Dry contact 2 state			1 bit	C	R	-	T	-

NO.	Object name	Function	Flags	Data type
0	General	Movement state	C R T	EIS1 DPT 1.001 1bit
This communication object is used for the presence detector detects something in its detection zone. It will be send OFF-“0” or ON -“1” to the bus cycle, until dose not detect any more movement. This function is often used to slave mode.				

Table 4.General object

NO.	Object name	Function	Flags	Data type
1	General	Brightness value	C R T	EIS5 DPT 9.004 2 byte
These communication objects is used for the Lux values into the valid range it will be report the current value to the bus only one times. and an external device can always read the current Lux values.				

Table 5 General object

NO.	Object name	Function	Flags	Data type
2	General	Temperature value	C R T	EIS5 DPT 9.001 2 byte

These communication objects is used for the temperature value is in the rang and changed , it will report the new temperature to the bus. and an external device can always read the current temperature.

Table 6 General object

NO.	Object name	Function	Flags	Data type
3,4	General	Dry contact state	C R T	EIS1 DPT 1.009 1bit

These communication objects is used for when the dry contact state changed, the state will be send telegrams to the bus.

Table 7 General object

4.2 All objects with Logical function “N”

Number	Name	Object Function	Description	Group Addresses	Length	C	R	W	T	U
10	Input A	Master mode			1 bit	C	R	W	T	U
11	Input A	External telegram			1 bit	C	R	W	T	U
12	Output A1	Switching			1 bit	C	R	-	T	-
13	Output A2	Absolute Dimming			1 Byte	C	R	-	T	-
14	Output A3	Shutter			1 bit	C	R	-	T	-
15	Output A4	Alarm			1 bit	C	R	-	T	-
16	Output A5	Percentage			1 Byte	C	R	-	T	-
17	Output A6	Sequence			1 bit	C	R	-	T	-
18	Output A7	Scene			1 Byte	C	R	-	T	-
19	Output A8	String (14 Byte)			14 Byte	C	R	-	T	-

4.2.1 Objects “Master mode”

NO.	Object name	Function	Flags	Data type
10,30, 50,70	Input A(B,C,D)	Master mode	C R W T U	EIS1 DPT 1.001 1bit

This communication object used for several presence detectors are used together in a room, slave sends **OFF** or **ON** telegrams cyclically (1 second)when it detects movement. The recovery time is restarted for the master after each **OFF** or **ON** telegram.

Table 8 Master mode

4.2.2 Objects “External telegram”

NO.	Object name	Function	Flags	Data type
-----	-------------	----------	-------	-----------

11,31, 51,71	Input A(B,C,D)	External telegram	C R W T U	EIS1 DPT 1.002 1bit
-------------------------	----------------	-------------------	-----------	---------------------------

This communication object is used to receive telegram from external device, The condition was reached by value “1”-True of receiving telegram; The condition wasn't reached by value “0”-False of receiving telegram.

Table 9 External telegram

4.2.3 Objects “Switching”

NO.	Object name	Function	Flags	Data type
12, ...	Output Nn	Switching	C R T	EIS1 DPT 1.001 1bit

This communication object is used for switching function, when the logic block was reached, it will send **ON** or **OFF** telegram to the bus. After the logic block wasn't reached and delay over, it will send **OFF** or **ON** telegram to the bus.

Table 10 Switching

4.2.4 Objects “Absolute Dimming”

NO.	Object name	Function	Flags	Data type
13, ...	Output Nn	Absolute Dimming	C R T	EIS2 DPT 5.001 1 byte

This communication object is used for absolute dimming function, when the logic block was reached, it will send setting value to control brightness. After the logic block wasn't reached and delay over, it will send another setting value.

Table 11 Absolute Dimming

4.2.5 Objects “Shutter”

NO.	Object name	Function	Flags	Data type
15, ...	Output Nn	Shutter	C R T	EIS1 DPT 1.008 1bit

This communication object is used for shutter function, when the logic block was reached, it will send **Up** or **Down** telegram to the bus. After the logic block wasn't reached and delay over, it will send **Down** or **Up** telegram to the bus.

Table 12 Shutter

4.2.6 Objects “Alarm”

NO.	Object name	Function	Flags	Data type
16, ...	Output Nn	Alarm	C R T	EIS1 DPT 1.005 1bit
This communication object is used for alarm function, when the logic block was reached, it will send Alarm or No alarm telegram to the bus. After the logic block was't reached and delay over, it will send No alarm or Alarm telegram to the bus.				

Table 13 Alarm

4.2.7 Objects “Percentage”

NO.	Object name	Function	Flags	Data type
17, ...	Output Nn	Percentage	C R T	EIS2 DPT 5.001 1 byte
This communication object is used for percentage function, when the logic block was reached, it will send setting value to control brightness. After the logic block was't reached and delay over, it will send another setting value.				

Table 14 Percentage

4.2.8 Objects “Sequence”

NO.	Object name	Function	Flags	Data type
18, ...	Output Nn	Sequence	C R T	EIS1 DPT 1.010 1bit
This communication object is used for Sequence function, when the logic block was reached, it will send Start or Stop telegram to the bus. After the logic block was't reached and delay over, it will send Stop or Start telegram to the bus.				

Table 15 Sequence

4.2.9 Objects “Scene”

NO.	Object name	Function	Flags	Data type								
19, ...	Output Nn	Scene	C R T	EIS14 DPT 17.001 1byte								
This communication object is used to control the scene. The scene control see following explain: Telegram value: <table border="1" style="display: inline-table; vertical-align: middle;"> <tr> <td>0</td><td>0</td><td>U</td><td>U</td><td>U</td><td>U</td><td>U</td><td>U</td> </tr> </table>					0	0	U	U	U	U	U	U
0	0	U	U	U	U	U	U					

U: Scene NO.(bin:000000...111111=NO.1...64)
<p>e.g: Hexadecimal</p> <p>00h-----call scene 1 (If scene allocated)</p> <p>01h-----call scene 2 (If scene allocated)</p> <p>3Fh-----call scene 64 (If scene allocated)</p>

Table 16 Scene

4.2.10 Objects “String(14 Byte)”

NO.	Object name	Function	Flags	Data type
20, ...	Output Nn	String(14 Byte)	C R T	EIS15 DPT 16.000 14 byte
<p>This communication object is used for string function, when the logic block was reached, it will send setting value to the bus. After the logic block was't reached and delay over, it will send another setting value.</p>				

Table 16 String(14 Byte)

5-Application

5.1 Program functions diagram

